

SPLIT HEAT PUMP WATER HEATER

INSTRUCTION MANUAL



Please read this manual thoroughly before undertaking installation or operation and keep in a safe place for future reference by a serviceman.

CONTENTS

1 INTRODUCTION	2
2 SAFETY PRECAUTIONS	2
3 CHECKING PRODUCT RECEIVED	3
3.1 Inspection and Storage	3
3.2 Handling the Unit	3
4 TECHNICAL SPECIFICATIONS	3
4.1 Electrical Physical Data	3
4.2 Dimension and Clearance	3
5 INSTALLATION INSTRUCTION	4
5.1 Locating Unit	4
5.2 Clearance and Access Panel	4
5.3 Piping Diagram	4
6 ELECTRICAL CONNECTION	6
6.1 Electrical Connection	6
6.2 Wiring Diagram	6
7 HOW TO USE	9
7.1 How to Use Remote Controller	9
8 BEFORE START-UP	10
9 AFTER START-UP	10
10 MAINTENANCE	10
11 TROUBLE SHOOTING	12

1 INTRODUCTION

These Heat pumps are used for residential or commercial application for domestic hot water and hydronic heating. Heat pump water heater can produce hot water to maximum 60°C with ambient temperature between -7°C~43°C.

2 SAFETY INFORMATION

ELECTRICAL POWER MUST BE ISOLATED BEFORE STARTING WORK ON THE EQUIPMENT.

This manual is intended to provide instructions for installation, commissioning and operation.

WARNING!

- 1.The installation, commissioning and maintenance of these units should be performed by qualified personnel having a good knowledge of standards and local regulations, as well as experience with this type of equipment.**
- 2.Any wiring used on site must comply with local electrical regulations.**
- 3.Ensure that the electrical supply corresponds to the specification indicated on the manufacturer requirement before proceeding with the connection in accordance with the wiring diagram supplied.**
- 4.The unit must be permanently grounded to avoid any risks caused by insulation defects.**
- 5.No wiring must come in contact with the heat source or the fan rotating parts.**
- 6.When preparing for shutting down the unit for a long period if the installation does not contain glycol, the condenser and the circled water pipes need to be carefully and completely drained of water.**

CAUTION!

- 1.The unit should be handled using lifting and handling equipment appropriate to the unit's size and weight.**
- 2.It is forbidden to start any work on the electrical components without switching off the electrical supply to the unit.**
- 3.It is forbidden to start any work on the electrical components if water or high humidity is present on site.**
- 4.When the unit is being connected, ensure that no impurities are introduced into the pipe work and the water circuits.**
- 5.The mesh filters must be provided on the hydraulic pump and in exchanger water inlets.**
- 6.The Manufacturer's warranty is void if the recommendations listed in this manual are not followed.**

3 CHECKING PRODUCT RECEIVED

3.1 Inspection and Storage

Upon receiving the equipment, all the items should be checked with the packing list to ensure that no items are missing. All units should be carefully inspected on receipt for any visible damage. In the event of shipping damage, inform the shipping company and lodge a complaint by registered letter. The manufacturer's warranty does not cover any physical damage to the unit after acceptance.

WARNING!

The sharp edges and surfaces of the coil fins can cause injury. Avoid contact with them.

3.2 Handling the Unit

Take care to avoid any sharp movements during the unloading and moving of the unit. Do not push or pull it by its base. Place a safety wedge between the unit base and the fork lift truck to avoid damaging the unit s structure and casing. Wedge is required along the entire length of the unit.

4 TECHNICAL SPECIFICATIONS

4.1Electrical and Physical Data

4.2Dimension and clearance

Please refer to Spec of each model for detail information.

5. INSTALLATION INSTRUCTION

5.1 Locating Unit

The units absorb the heat from the ambient air. Because of this, they should be installed outdoors or some places with sufficient space to provide free air circulation through the evaporator coil. Any ventilation restrictions will reduce the air flow, then decrease the heating capacity.

It is prohibited to connect the outdoor axial fan to air ductwork because of pressure drops created by such ductwork. If want to use cool air, a additional booster fan must be installed.

In case the unit is located in an area exposed to high wind, it's necessary to install near a vertical wall, so the unit is not in direct wind current.

Install sound isolator pad to reduce vibration and sound.

5.2 Clearance and Access Panel

After installation, all sides of the unit must be accessible for regular maintenance and service. Please refer to Spec of each model for detail information.

Note:Before installation, please open access panel to take out the controller and support bracket,etc.

WARNING!

The grille is intended to protect operators from risks of injury from the fan blade during installation and maintenance.

However, it can cause clogging with frost or ice on heat machines installed in cold or mountainous regions.

To avoid such a risk,a shelter must be provided, or the protective grille can simply be removed.

5.3 Piping Diagram

Install flow switch (if required) at outlet pipe and wire it to PCB inside heat pump.

Install Y strainer(40-60 mesh) at inlet. Clean it regularly.

1) For split heat pump water heater without built-in water pump:

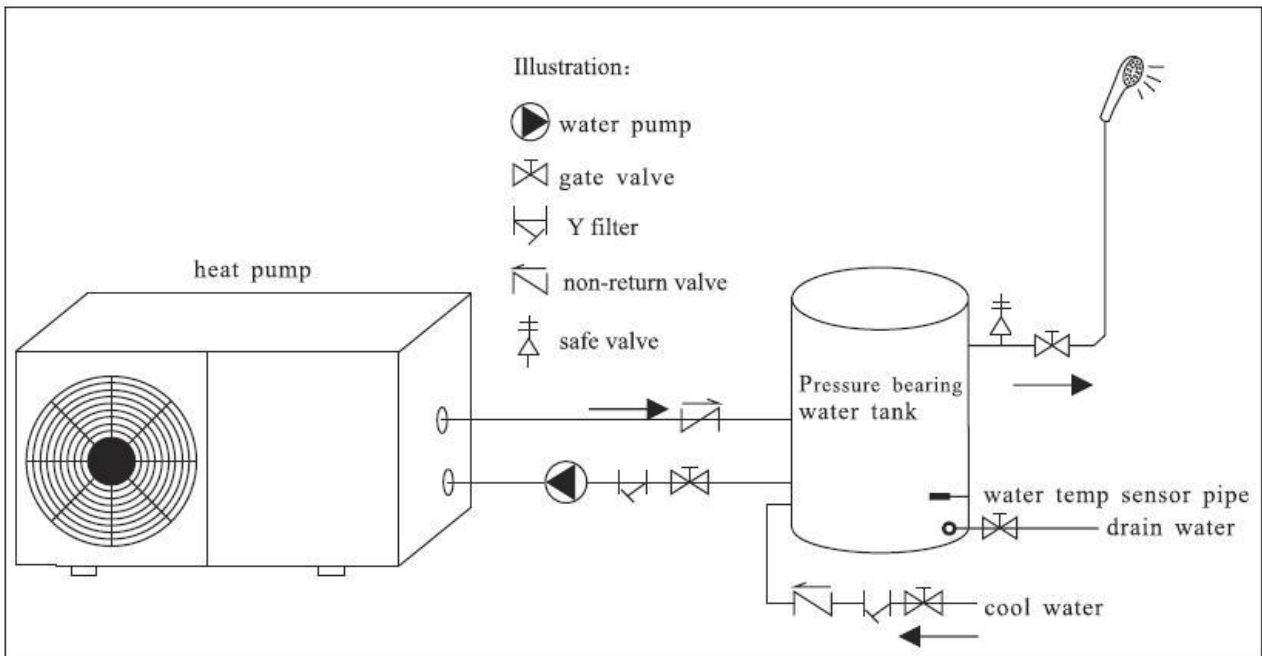

2) For split heat pump water heater with built-in water pump:

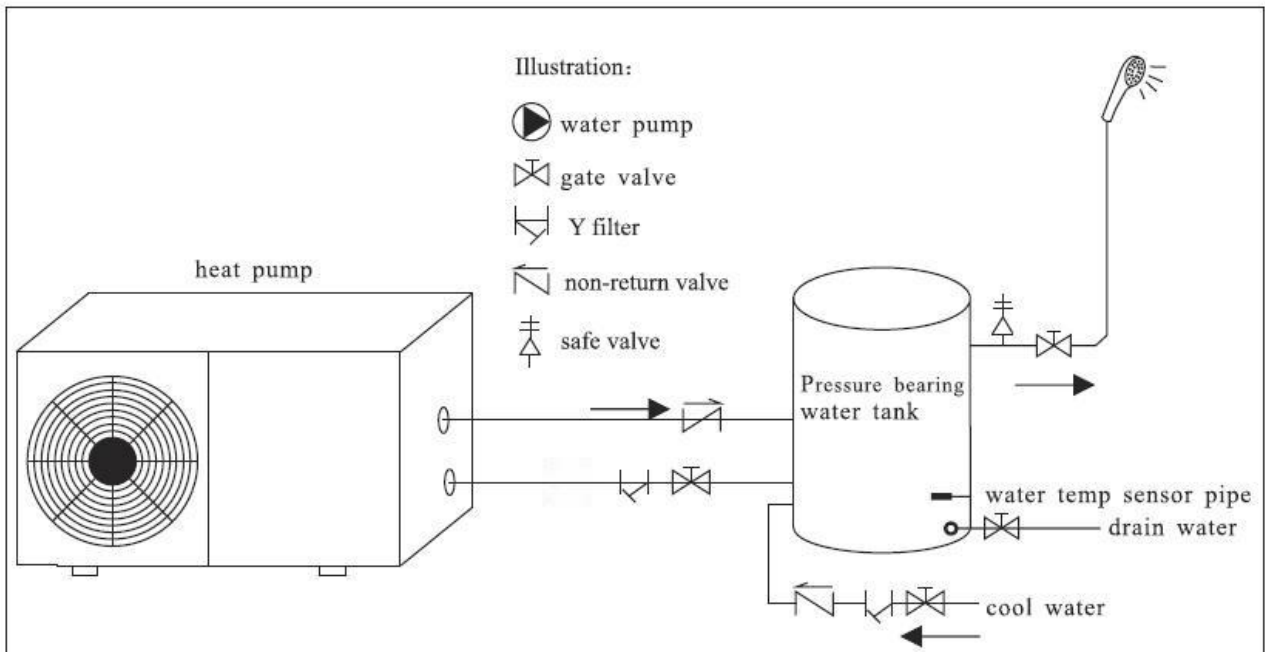

This diagram is a recommendation and is not intended to replace an engineered piping system by a professional engineer.

6 ELECTRICAL CONNECTION

6.1 Electrical Connection

Before starting any electrical connection, check that electrical supply corresponds to the specification indicated on the unit's rating plate and to the unit's electrical characteristics table.

Importance: it is the responsibility of the installer to provide circuit breaker protection, corresponding to the machine's capacity (refer to the electrical specification table or the label pasted on the heat pump).

Connection to the electrical network must comply with current electrical standards,

WARNING!

Site wiring must be carried out in accordance with the wiring diagram affixed to the unit's junction box.

The power cables for general power supply to the unit must have a copper core, with dimension in accordance with current IEC standards and any applicable code.

The unit must be permanently grounded via a terminal block provided inside the junction box.

The supply voltage must not vary by more than 10%. Imbalance between the phases must not be more than 3%.

All the connections are made on screw terminals.

6.2 Wiring Diagram

These wiring diagram are just for reference. Please refer to the wiring diagram label on the machine.

1) For split heat pump water heater without built-in water pump:

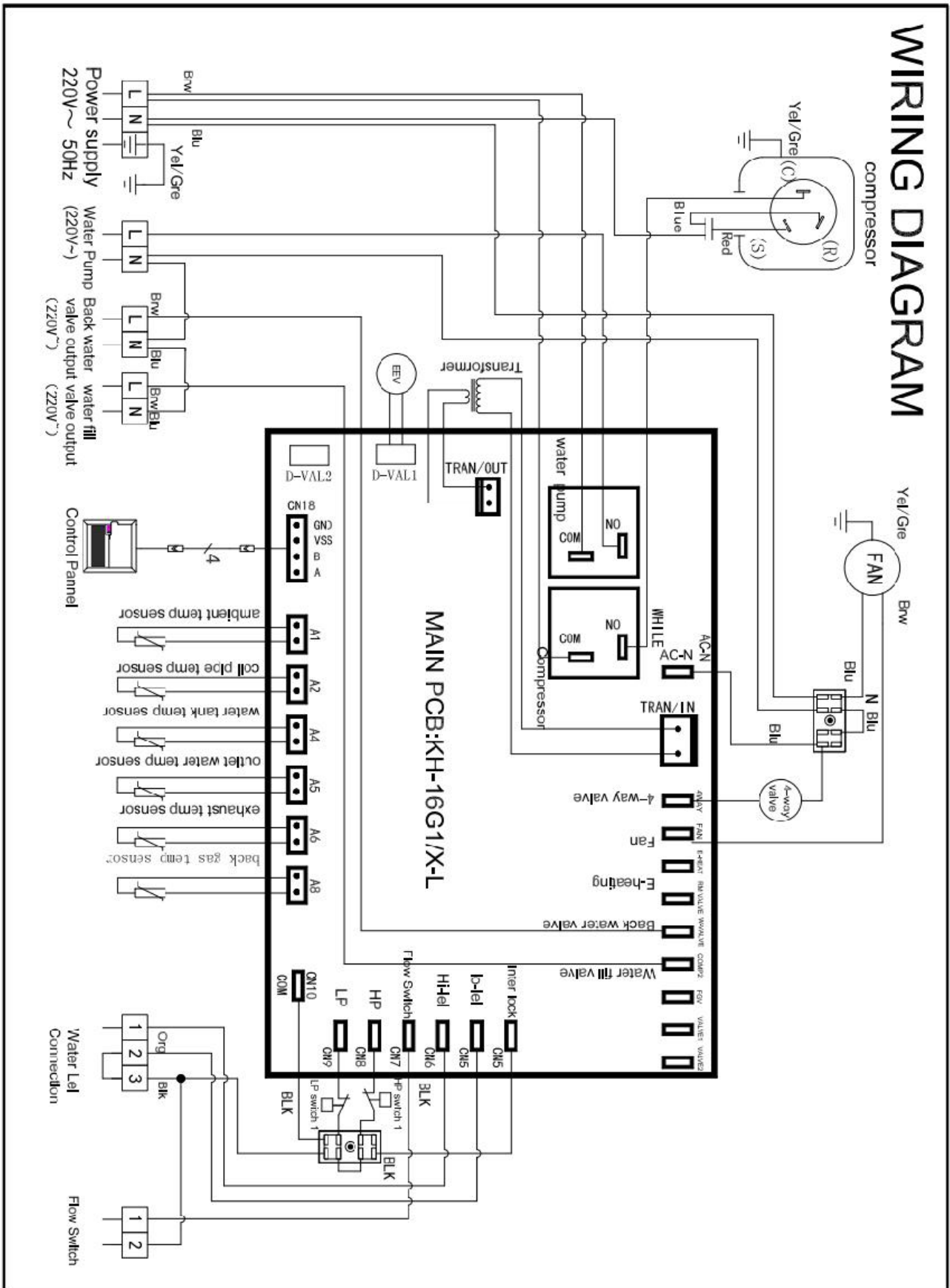

7 HOW TO USE

7.1 how to use remote controller

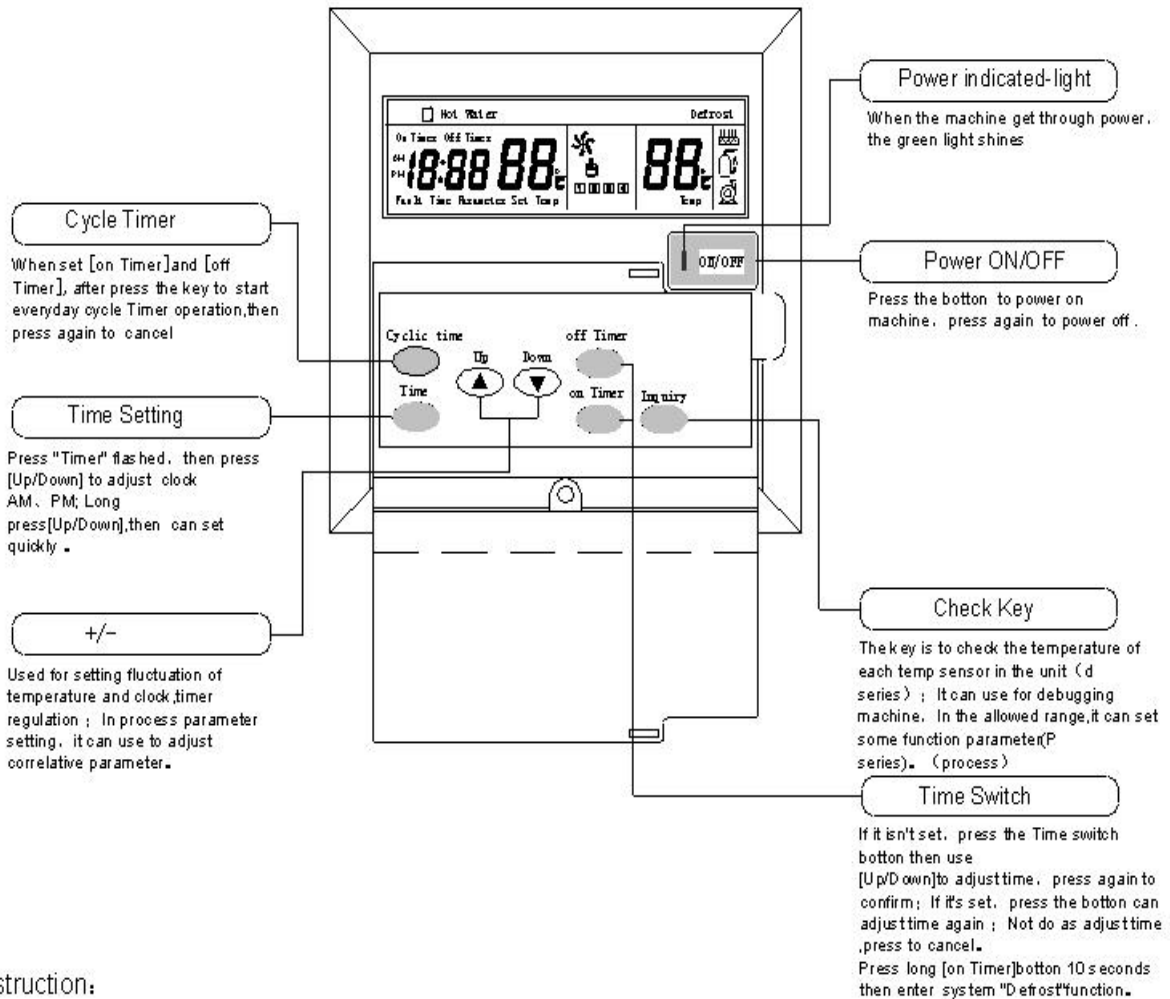

Instruction:

1. water temperature indication

Water temperature indication: when the system standby or power on, there are two temperature on the screen, one is current temperature, one is setting temperature.

2. Inquiry key operation instruction

A. Press (Inquiry) button, check the temperature of each temp sensor d01, d02.....

B. Long press button to adjust some run parameter setting some parameter, refer to factory before adjust it (parameter adjust improper, it maybe effected system), if it's not special condition, user not need to adjust

3. Time or Timer setting

Set the time of (Time), (on timer), (off Timer), when the icon flash on the screen, press (up/down) button to set the time, long press (up/down)

4. Controller panel fixation

Used M4 bolt that is in lashing eye to put pannel to install on back iron rack.Please pay attention: if the bolt is screwed too tightly, which would result control botton blocked,malfunction that it can't operate normally.

8 BEFORE START-UP

Flush system before putting into operation to ensure that foreign material does not damage pump seals.

Before start-up, water should be flowing through the heater.

Check the HPWH system:fix all the screw, check the communicate indicator on the control panel, check high/low pressure. When the pressure exceed the max, turn offer the power and check the system.

Check drain pipe before start-up.

9 AFTER START-UP

After the compressor working, check the operation sound. If there is abnormal sound, turn off and check the system. If the sound is normal, check the system pressure.

Check thank water temperature. The tank water temperature can be checked on remote control panel.

The default setting is factory setting.it is no necessary for end user to adjust.

Check whether water flow meet the unit's requirement.

10 MAINTENANCE

CAUTION!

Before proceeding with any maintenance on unit, be sure that the electrical supply is switched off.

Serving and maintaining the units must be carried out by qualified air conditioning technicians.

Repeated tripping of safety and control devices must be thoroughly investigate and corrected before any further re-occurrence.

However, it is advisable to carry out a certain number of preventive operations in order to maintain the unit in optimum working order.

These operation essentially consist of stand checks(checking operation temp setting, checking voltages and currents, checking water flow and temperature, etc...)and should be carried out every 6 months.

PREPARATION FOR SHUTTING DOWN THE UNIT FOR A PROLONGED PERIOD

The following recommendations should be taken into consideration; After stopping the compressor, stop the circulation pump. If installation does not contain glycol, the condenser and the hot water pipes need to be carefully and completely drained of water in areas with low temperature.

FAN BEARINGS

The fan bearings are greased for life. These bearings require no greasing. However, check every 6 months and make sure there is no abnormal wear on these moving parts

ELECTRICAL TERMINALS

Check the screw terminal block every 6 months

EVAPORATOR COIL

The evaporator coil do not require any special maintenance, expect when they are clogged by debris. In corrosive environment,suitable protection should be provided. Cleaning can be done by washing with suitable detergent solution,and then rinsing with clean water.

CONDENSER

The condenser is a tube in tube heat exchanger. These condenser require no special maintenance, but a strained should be installed in order to prevent the ingress of impurities which could clog the condenser. Regularly back wash and chemical wash heat exchanger.

EXPANSION DEVICE

The expansion device requires no specific maintenance.

PUMP

The pump requires no specific maintenance.

STORAGE TANK

Storage tank should be cleaned regularly

REFRIGERANT CHARGE

The needle valve at suction pipe nearby compressor can be used for refrigerant charge.

11 TROUBLE SHOOTING(ERROR CODE INDICATION)

The following recommendations should be taken into consideration.

Code	Description	Possible cause	Remedies
E01	Water temp sensor error	Water temp sensor is open or shorted circuit	Check and replace sensor
E02	Ambient temp sensor error	Ambient temp sensor id open or shorted circuit	Check and replace sensor
E03	System 2 evaporator temp sensor error	Evaporator temp sensor open or shorted circuit	Check and replace sensor
E04	Water flow switch protection error	1.defective water flow switch 2.Water pump not start 3.Water flow not enough 4.Water pipe jammed	1.check or replace water flow switch 2.Check or replace water pump 3.Clean water pipe and filter
E05	System 1 high pressure protection	1.Defective high pressure protection 2.Water-flow not enough	1.check or replace high pressure switch 2.Clean water pipe and filter
E06	System 1 low pressure protection error	1.Defective low pressure protection switch 2.Lack of refrigerant	1.check or replace low pressure switch 2.Recharge refrigerant
E07	Outlet water temp sensor error	Outlet water temp sensor is open or shorted circuit	Check and replace sensor
E08	Water level probe protection for low water	1.lack of water in water tank 2.Water level probe open circuit	1.check or clean make-up water pipe and make-up water valve 2.Check water level probe and reset
E09	Temp difference protection	1.excessive difference between inlet water temp 2.Water floe not enough	1.clean water pipe and filter 2.Check or replace water pump
E10	Communication error	Control panel wire lose connection or open circuit	1.check control panel 2.Replace control panel or PBC
E11	System 2 evaporator temp sensor error	Evaporator temp sensor open or shorted circuit	Check and replace sensor
E12	System 2 high pressure protection error	1.defective high pressure protection 2.Water-flow not enough	1.check or replace high pressure switch 2.Recharge refrigerant
E13	System 2 low pressure protection error	1.Defective low pressure protection switch 2.Lack of refrigerant	1.check or replace low pressure sensor 2.Recharge refrigerant

E14	System 1 high discharge temp protection	1.discharge temp too high 2.Lack of refrigerant	1.replace compressor lubricator 2.Recharge refrigerant or turn up metering valve
E15	System 2 high discharge temp protection	1.discharge temp too high 2.Lack of refrigerant	1.replace compressor lubricator 2.Recharge refrigerant or turn up metering valve
E16	System 1 discharge temp sensor error	Discharge temp sensor is open or shorted circuit	Check and replace sensor
E17	System 2 discharge temp sensor error	Discharge temp sensor is open or shorted circuit	Check and replace sensor
E18	Outlet high temp protection error	Direct-heating heat pump outlet temp too high	1.increase inlet water flow or replace inlet water pump 2.Recharge refrigerant

Warranty Certification

CUSTOMERS COPY (PLEASE KEEP IN A SAFE PLACE WITH PROOF OF PURCHASE)

Model & Serial No. : _____

Customer Name : _____

Address : _____

Telephone No. : _____ Handphone: _____

Email : _____

DEALER TO COMPLETE

Date of Purchase

--	--	--	--	--	--	--	--

DAY MONTH YEAR

Warranty Void: If card is improperly filled, defaced, erase or altered in any manner.

DEALER'S NAME AND ADDRESS/STAMP
